

# Grand Meyer®

The heating of life

## Sistema di riscaldamento a pavimento THC20

Sistema di riscaldamento via cavo  
Manuale di installazione

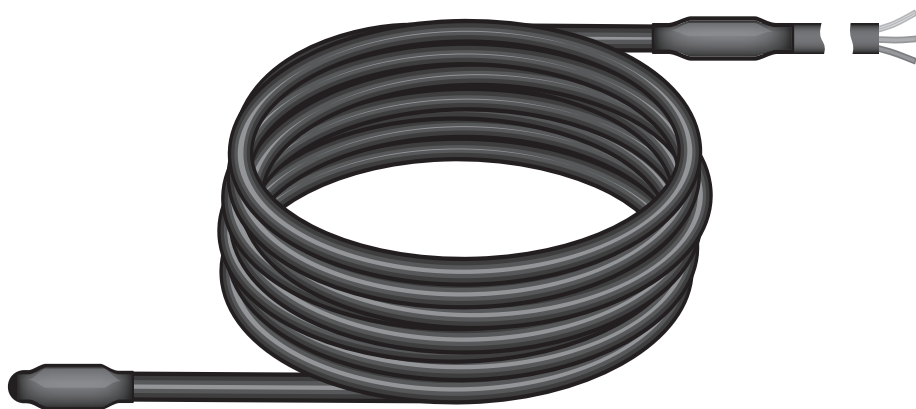

Scansiona per trovare il  
manuale in altre lingue.



## CONTENUTO

1. DISPOSIZIONI GENERALI E RACCOMANDAZIONI .....	2
2. SCOPO .....	2
3. EQUIPAGGIAMENTO* .....	3
3.1 SET DI CAVI RISCALDANTI ASSEMBLATO IN FABBRICA .....	3
3.2 STRUTTURA DEL CAVO RISCALDANTE .....	4
3.3 INSTALLAZIONE CON NASTRO DI FISSAGGIO .....	4
4. PRIMA DELL'INSTALLAZIONE .....	5
4.1 DETERMINAZIONE DEL PUNTO DI INSTALLAZIONE DEL TERMOSTATO .....	6
4.2 ISOLAMENTO TERMICO .....	6
4.3 TAGLIO CONSIGLIATO DEL SISTEMA RADIANTE A PAVIMENTO .....	7
4.4 FASI DI INSTALLAZIONE DEL CAVO RISCALDANTE .....	8
5. INSTALLAZIONE .....	9
5.1 GUIDA PASSO-PASSO PER L'INSTALLAZIONE .....	10
6. AVVIO DEL SISTEMA DI RISCALDAMENTO A PAVIMENTO .....	12
7. NORME DI FUNZIONAMENTO E SICUREZZA .....	13
8. GARANZIA .....	15
9. CERTIFICATO DI GARANZIA .....	16
PLANIMETRIA .....	17
SPAZIO PER APPUNTI .....	18



Gentile Cliente, grazie per aver scelto un prodotto Grand Meyer. Siamo certi che i nostri prodotti soddisferanno le sue aspettative e manterranno la sua casa calda. Si prega di leggere attentamente le istruzioni prima di iniziare l'installazione. Il mancato rispetto delle regole e delle raccomandazioni per l'installazione del sistema di riscaldamento a pavimento può comportare guasti al sistema o una diminuzione dell'efficienza.

## **1. DISPOSIZIONI GENERALI E RACCOMANDAZIONI**

Prima di installare il cavo riscaldante, assicurarsi che il sistema scelto sia adatto per l'ambiente, tenendo conto della sua superficie.

Le istruzioni illustrano in dettaglio l'installazione e il collegamento del sistema di riscaldamento a pavimento Grand Meyer, poiché il funzionamento a lungo termine del riscaldamento dipende in gran parte da una corretta installazione.

Installare il sistema in stretta conformità con questo manuale.

L'installazione e il collegamento del cavo riscaldante devono essere eseguiti da uno specialista qualificato.

## **2. SCOPO**

Il riscaldamento a pavimento Grand Meyer è un sistema di riscaldamento elettrico a cavo per ambienti, da installare in uno strato di massetto sabbia-cemento con un'altezza di almeno 3 cm.

Il sistema di riscaldamento a pavimento Grand Meyer, basato sul cavo riscaldante THC20, è progettato per garantire il comfort termico negli ambienti e per:

- garantire una temperatura confortevole della superficie del pavimento;
- oppure riscaldare l'intero ambiente (come fonte principale o aggiuntiva di calore).

Il sistema di riscaldamento a pavimento, destinato al riscaldamento principale, deve coprire almeno il 70% della superficie totale dell'ambiente. L'altezza del soffitto non deve superare i 4 m.



### 3. EQUIPAGGIAMENTO \*

Il set Grand Meyer basato sul cavo riscaldante THC20 include:



1. Set di cavo riscaldante assemblato in fabbrica THC20 con cavo freddo da 3 m.



2. Tubo corrugato Ø 16 mm, lunghezza 1,5 m con tappo all'estremità. Il tubo serve per il montaggio del sensore di temperatura.



3. Istruzioni di installazione e uso.

4. Scheda tecnica del set di cavo riscaldante assemblato in fabbrica THC20 con le sue caratteristiche tecniche.

\* Oltre al set, è necessario selezionare un termostato ambiente (non incluso nel set).

#### 3.1. SET DI CAVO RISCALDANTE ASSEMBLATO IN FABBRICA.

Il set di cavo riscaldante a pavimento assemblato in fabbrica (di seguito «cavo riscaldante») è basato su conduttori riscaldanti isolati a doppio conduttore, dotato di un cavo freddo per l'installazione lungo 3 m per il collegamento all'alimentazione principale.

La potenza specifica del cavo è di 20 W/m alla tensione principale di ~230 V. I dati tecnici del cavo riscaldante a pavimento THC20 sono presentati nella tabella 1.

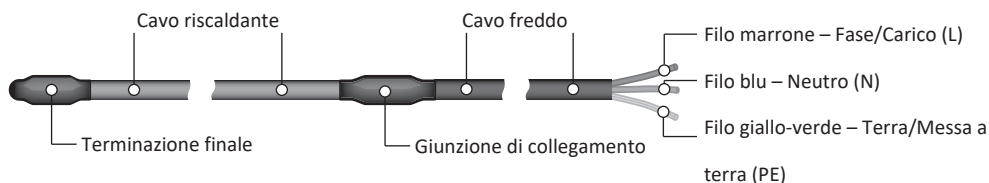

Quando si collega il cavo riscaldante alla rete:

- filo marrone e filo blu – conduttori di riscaldamento (carico),
- filo giallo-verde – schermatura (conduttore di messa a terra della rete di alimentazione – PE).



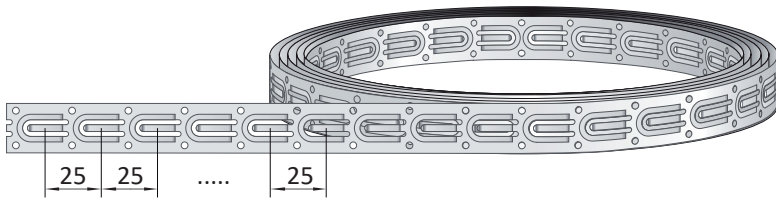

- 
- 

*\* Il nastro di fissaggio non è incluso nel set del cavo riscaldante a pavimento Grand Meyer THC20.*

#### 4. PRIMA DELL'INSTALLAZIONE

P

. I T

. P

N

. I

. A

. I

IE

. I



Qualsiasi cavo riscaldante deve essere collegato tramite un dispositivo di corrente residua (RCD) con una corrente nominale di intervento non superiore a 30 mA.

Tabella 2. Parametri dei cavi elettrici standard.

Materiale conduttore	Sezione, mm <sup>2</sup>	Corrente massima, A	Potenza totale (max), W
Rame	2x1,0	16	3500
	2x1,5	19	4100
	2x2,5	27	5900
Alluminio	2x2,5	20	4400
	2x4,0	28	6100

Quando il sistema di riscaldamento a pavimento viene installato in ambienti umidi (bagni, saune, piscine), il filo di drenaggio del cavo riscaldante deve essere collegato al conduttore di messa a terra. Il termostato ambiente deve essere installato al di fuori dei locali con elevata umidità (bagni, toilette, saune, piscine).

#### **4.1. DETERMINAZIONE DEL LUOGO DI INSTALLAZIONE DEL TERMOSTATO**

Il termostato deve essere installato al di fuori delle aree ad alta umidità. L'altezza di installazione consigliata è di 0,8 m dalla superficie del pavimento. È auspicabile che il termostato sia facilmente accessibile per modificare il livello di temperatura o le impostazioni del programma.

#### **4.2 ISOLAMENTO TERMICO**

Al fine di ridurre le perdite di calore per il riscaldamento del pavimento, del terreno e di altre strutture sottostanti, prima di installare il sistema di riscaldamento a pavimento è necessario scegliere e installare correttamente l'isolamento termico. Con il suo aiuto è possibile ridurre in modo significativo il consumo di elettricità del sistema.

Se il riscaldamento a pavimento viene utilizzato come sistema di riscaldamento principale, si consiglia di utilizzare pannelli rigidi di polistirene espanso (EPS) con uno spessore di almeno 20 mm e una densità di almeno 35 kg/m<sup>3</sup>.

L'isolamento termico deve essere utilizzato in tutti i casi in cui il pavimento si trovi vicino al suolo o in un seminterrato.



For basements, garages and other premises where the floor is in direct contact with the ground, it is recommended to use rigid foam or mineral wool boards with a thickness of 30 mm or more.

The insulation material is laid or glued to the concrete floor. To prevent deformation of the floor during heating, shock-absorbing strips of sheet foam are glued around the perimeter of the room. The thermal insulation layer is poured with a floor leveler and a screed is made.

Without additional thermal insulation, the heating time of the floor increases.

The thinner the layer of additional thermal insulation, the more heat is lost downwards, and the less heat is released into the room.

If there is a warm room under you, then the thermal insulation may not be laid, but in any case, the best solution is to isolate the warm plate with a heating cable from the concrete base, as it increases the efficiency of the system.

### 4.3 RECOMMENDED CUT OF THE FLOOR HEATING.

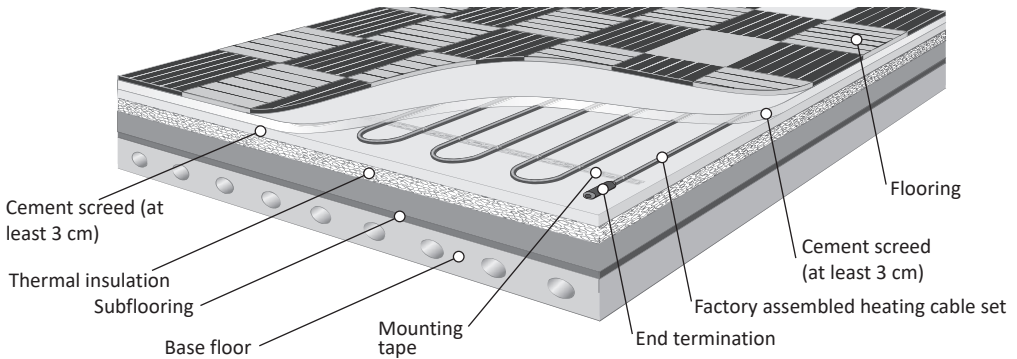

Laminate, linoleum, carpeting, etc. can act as a decorative coating.

If ceramic tiles are used, they are usually attached to the screed with a heating cable using tile adhesive.

If ceramic tiles are used, the heating cable must not be laid directly into the tile adhesive layer, except for a cement screed. This can lead to cracking of the floor surface and failure of the heating cable.



If the floor heating system is used to ensure a comfortable temperature of the floor surface and there is a warm room below, for example, a city apartment (not the first floor), then the thermal insulation can not be laid.

#### 4.4 INSTALLATION STEP OF THE HEATING CABLE.

Before starting installation, after choosing the heating cable you need, you need to determine its laying step, which can be calculated using the formula:

**STEP** laying (cm) = **(100 x S) / L cable**, where

**S** - is the actual area on which the heating cable is laid (m<sup>2</sup>),

**L cable** - is the length of the heating cable (m).

The calculated laying step is rounded up to a multiple of 2,5 cm, since the clamps on the applied mounting tape, into which the heating cable is attached, are located 2,5 cm apart.

It should be noted that the above formula does not take into account the length of the cable bends at the turns.

For a more correct calculation of the heated area, we recommend to use the drawing software.

Depending on the specific power (type of heating - maintaining a comfortable floor temperature or main heating) of the heating cable system, the heating area and the step of laying the heating cable depend. This dependence is shown in Table 3.

Table 3. Recommendations for the selection of heating cables.

Article	Length, m	Power, W	Max. heating area (m <sup>2</sup> ) at laying step (specific power, W/m <sup>2</sup> )				
			7,5 cm 267 W/m <sup>2</sup>	10 cm 200 W/m <sup>2</sup>	12,5 cm 160 Вт/м <sup>2</sup>	15 cm 133 W/m <sup>2</sup>	17,5 cm 114 W/m <sup>2</sup>
THC20-10	10	200	0,75	1,00	1,25	1,50	1,75
THC20-15	15	300	1,13	1,50	1,88	2,25	2,63
THC20-23	23	460	1,73	2,30	2,88	3,45	4,03
THC20-32	32	640	2,40	3,20	4,00	4,80	5,60
THC20-45	45	900	3,38	4,50	5,63	6,75	7,88
THC20-57	57	1 140	4,28	5,70	7,13	8,55	9,98
THC20-70	70	1 400	5,25	7,00	8,75	10,50	12,25
THC20-85	85	1 700	6,38	8,50	10,63	12,75	14,88
THC20-98	98	1 960	7,35	9,80	12,25	14,70	17,15
THC20-115	115	2 300	8,63	11,50	14,38	17,25	20,13
THC20-160	160	3 200	12,00	16,00	20,00	24,00	28,00



## 5. INSTALLATION.

***The installation of the heating cable must be carried out by a qualified specialist, the connection of the underfloor heating cable system to the electrical network must be carried out by a certified electrician.***

The heating cable is laid on open flooring surfaces. The laying step must be such that the power per unit area corresponds to the calculated one - see section 4.4 (table 3) of this Instruction.

The heating cable is laid on a flat floor base, without significant protrusions and height differences. If there are protrusions and height differences, the thickness of the subsequently poured screed will be different over the entire floor heating area, which will lead to uneven heating of the floor.

For correct and reliable fastening of the heating cable, a mounting tape with a fixing pitch of 2,5 cm is used (see cable 3.3). The mounting tape is attached to the floor in any way - with nails, dowels, glue, etc., in increments of 50 - 150 cm, depending on the configuration of the room. Permissible bending diameter of the fixed cable - 6 cm.

The distance between the lines of the heating cable should be no more than 18 cm, otherwise a temperature difference will be felt on the floor surface - alternation of warm and cold zones. For wet rooms, a laying step of no more than 15 cm is recommended.

Between the lines of the heating cable, a corrugated tube is laid and fixed, inside which a temperature sensor is installed. Along the corrugated tube in the wall, the sensor, together with the installation conductor of the heating cable, is led to the place where the thermostat is installed. The corrugated tube must be plugged from the side of the sensor to prevent the solution and moisture from getting inside when pouring the screed.

Immediately after the installation of the floor heating is completed, it is necessary to draw the final laying plan with binding in place, indicating the location of the joint and end sleeves, temperature sensor, lines of the heating cable.

The laid and securely fixed heating cable is poured with a cement screed, the thickness of which should be from 30 to 50 mm.

Cement screed should not have sharp stones and air pockets, so as not to damage the heating cable and prevent it from overheating.



In the process of laying the heating cable it is necessary to control the integrity of the cable and the corrugated tube.

### **Attention!**

It is forbidden to turn on the heating cable until the screed is completely hardened. Generally, this time is 30 days.

## **5.1 STEP-BY-STEP INSTALLATION GUIDE.**



**1.** Cut through a 2,5 x 2,5 cm heating cable in the wall and floor. It is necessary for laying the temperature sensor, the installation conductor and for installing the mounting box for room thermostat (Fig. 1).



**2.** Clean the base on which the heating cable is laid from garbage and sharp objects (Fig.2).



**3.** Fasten the mounting tape to the floor (Fig. 3).

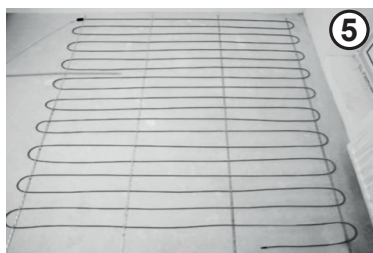

**4.** Lay out the heating cable evenly in loops over the surface of the entire floor, avoiding pipes and areas intended for bathrooms, cabinets, etc. Fasten the heating cable to the mounting tape using special clamps. The lines of the heating cable must not intersect or touch each other (Fig. 4, 5).

***To prevent longitudinal movement of the heating cable due to heating during operation, it should be laid in one direction for a length of no more than 6 m.***



**5.** After laying the heating cable, check electrical resistance measure. The electrical resistance of the heating cable must match the specified in the technical data sheet for the heating cable. Allowed deviation from the specified parameters -5% - +10% at  $t = 20 \pm 1^\circ\text{C}$  (Fig. 6).



**6.** Place the floor temperature sensor in a corrugated pipe, plugged at one end to prevent mortar and moisture from getting inside when pouring the screed, and place it between the heating cable lines on the open side of the loop at a distance of 50 - 60 cm from the wall (Fig. 7).

Lay the corrugated pipe with cold lead of the heating cable in a chase in the wall leading to the junction box.



**7.** Connect the cold lead of the heating cable with the room thermostat. (Fig. 8).

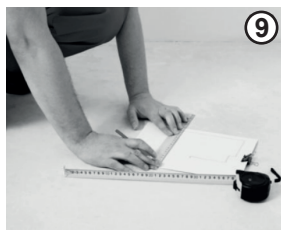

**8.** Draw the room plan with heated area location, indicating the heating cable end and splices, temperature sensor and the place of connection to the power supply (Fig. 9). If heating cable breakdown will be made during installation, it will help to identify breakpoint to fix the heating cable.

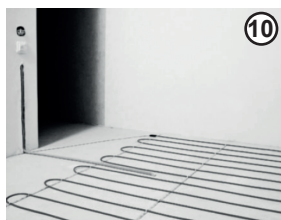

**9.** After installation (Fig. 10), lay the cement screed on the heating cable. The heating cable, end and splices must be completely filled. In case of incorrect filling or poor-quality of the screed, air pockets can form around the cable which can lead to an excess of the permissible temperature on the cable surface and, consequently, to its damage.

**10.** Check measure of the electrical resistance of the heating cable after pouring the screed again.

**11.** After the screed has completely hardened (usually 30 days), you can turn on the warm floor.

## **6. STARTING USE THE UNDERFLOOR HEATING.**

You can turn on floor heating after the tile adhesive has completely dried (you can specify this parameter in the technical specifications on the package of the tile adhesive). Turn on the room thermostat and set the desired temperature on it, using the instructions of room thermostat\* (not included in the set).

When you turn on the floor heating for the first time after installation,



you can set the maximum level of heating and, after reaching a comfortable temperature, reduce the level. When you turn on the floor heating for the first time, it can take up to 48 hours to reach desired temperature, depending on the parameters of the room.

## **7. OPERATING RULES AND SAFETY.**

- The braided shield of the heating cable power cable must be permanently and securely connected to the earth terminal in the junction box or to the appropriate terminal on the thermostat.
- On the floor made of materials with good thermal conductivity (ceramic tiles, natural stone, etc.), under which the floor heating cable is installed, there should not be any other coatings and objects (carpets, blankets, etc.) that prevent heat transfer, to avoid cable overheating.
- The heating cable must be at least 50 mm away from walls, furniture and any other objects that prevent effective heat release into the air.
- When installing the heating cable, direct contact with the thermal insulation, if it is corrosive, hygroscopic or flammable, must be excluded.
- The surface of the floor with installed heating must not be subjected to mechanical stress (it is forbidden to hammer nails, dowels or screw in screws, etc.) in order to avoid damage to the heating cable and temperature sensor.
- In case of a long absence from the room during the cold season, we recommend disconnecting the system from the power supply or not turning off the heating completely, but setting it to the minimum level. In this case, the system consumes little energy, and the room will not be completely cold and it can be heated up more quickly after your return.
- It is forbidden to make any changes to the design of the heating cable received from the manufacturer, with the exception of cutting the mesh when laying.
- It is forbidden to replace the installation wires yourself by breaking the connections in the coupling made by the manufacturer.
- It is forbidden, even for a short time, to turn on the heating cable rolled into a roll into the electrical network.



- It is forbidden to connect heating cable to the electrical network, the voltage in which does not correspond to the operating voltage specified in the technical data sheet for the heating cable.
- The heating cable must be connected by a qualified certified electrician.
- During installation, the heating cable must not be exposed to oil, grease or other similar substances.
- To avoid mechanical damage to the heating cable, installation must be carried out in shoes with soft springy soles or cover the surface with the heating cable laid out on it with plywood sheets or some other materials that prevent mechanical impact on the heating cable when walking on it.
- It is forbidden to use heating cable without a minimum layer of tile mixture that completely covers the heating cable. The thickness of the tile mixture should be 5-8 mm, the formation of bubbles and the rise of the heating cable are not allowed.
- It is forbidden to subject the floor surface under which the heating cable are installed to any mechanical influences.
- If any of the above requirements is violated, the manufacturer will void the warranty.



## 8. WARRANTY.

**The manufacturer guarantees the operation of the THC20 heating cable for 20 years, subject to compliance with all the requirements set forth in this Installation and Safety Manual.**

The manufacturer undertakes to carry out a warranty repair of the heating cable if all the requirements for installation and operation rules are met, upon presentation of the completed Warranty Certificate and the Room Plan indicating the location of the room thermostat, heating cable, splice, end sleeves and floor temperature sensor.

Products with defects resulting from mechanical damage or improper connection and operation of the heating cable are not subject to warranty repair.

MANUFACTURER:

SIA «PRIOTHERM»

Address: st. Augusta Deglava 50, Riga, LV-1035, Latvia.

[info@grand-meyer.com](mailto:info@grand-meyer.com)

[www.grand-meyer.com](http://www.grand-meyer.com)



## 9. WARRANTY CERTIFICATE.

Heating cable used for Comfort/Basic heating.  
(cross out the unnecessary)

Room type \_\_\_\_\_

Total room area \_\_\_\_\_ m<sup>2</sup>

Floor heating is installed on the square \_\_\_\_\_ m<sup>2</sup>

Heating cable \_\_\_\_\_  
(Article)

Presence of thermal insulation (YES/NO), its type and thickness \_\_\_\_\_  
(cross out the unnecessary)

Sale made \_\_\_\_\_

Contact number \_\_\_\_\_

Date of sale \_\_\_\_\_ 20\_\_\_\_ r.      Seller \_\_\_\_\_  
(signature)

Shop stamp \_\_\_\_\_      Buyer \_\_\_\_\_  
(signature)

System installed \_\_\_\_\_

Contact number \_\_\_\_\_

Installation date \_\_\_\_\_ 20\_\_\_\_ r.      Installer \_\_\_\_\_  
(signature)

The floor plan is attached.

# Room plan.

Room plan indicating the location of the temperature regulator, floor temperature sensor, heating cable, connection splice and end termination for installation purposes and for searching of possible defects.

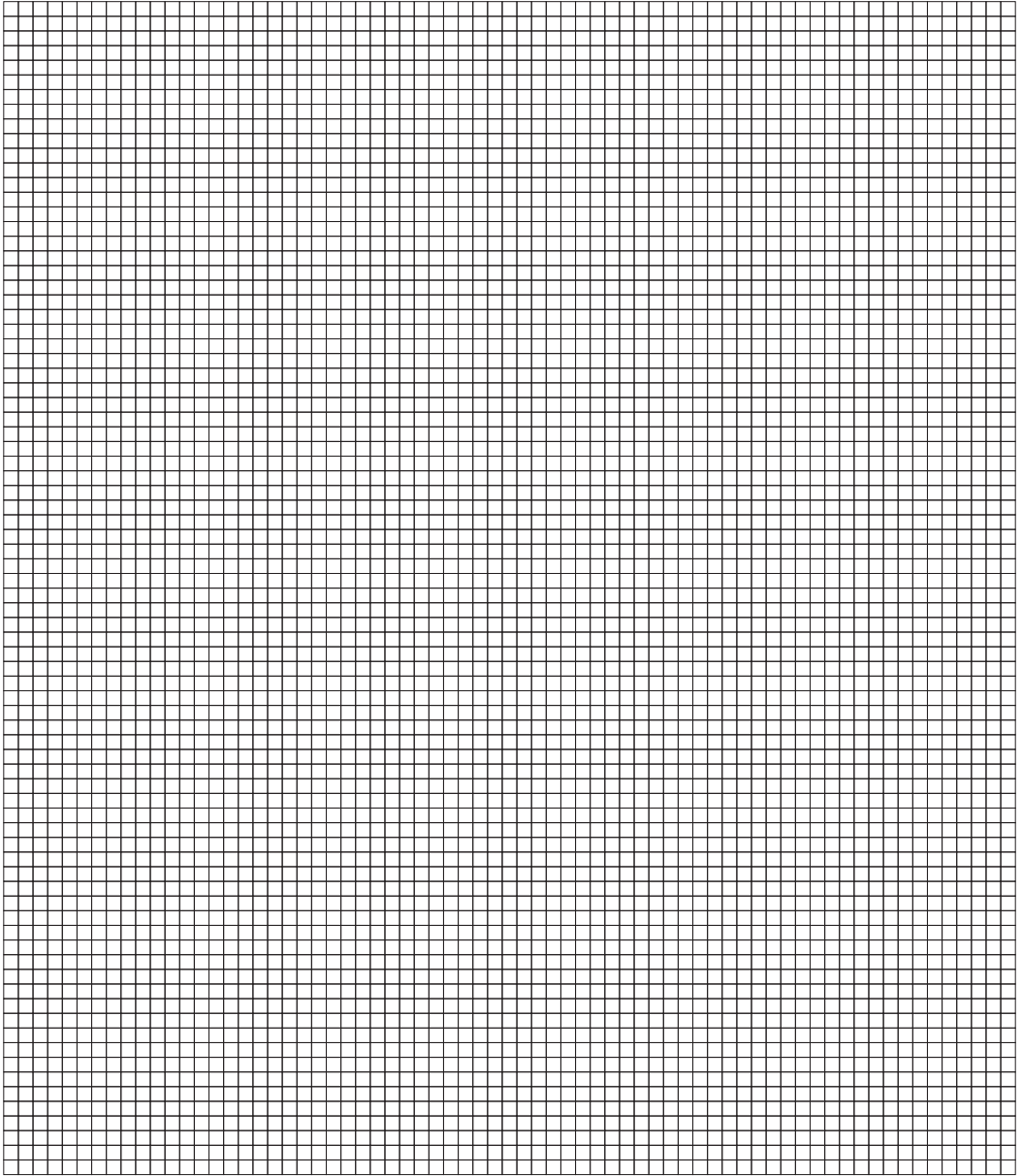

## Type codes

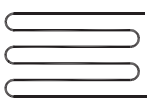

Heating cable

Corrugated tube for temperature floor sensor

R heating cable ..... Ohm



Temperature Sensor



Room Thermostat



Connection Splice



End Termination

R sensor ..... Ohm



