

Grand Meyer®

The heating of life

Vloerverwarmingssysteem THC20

Kabelverwarmingssysteem Installatiehandleiding

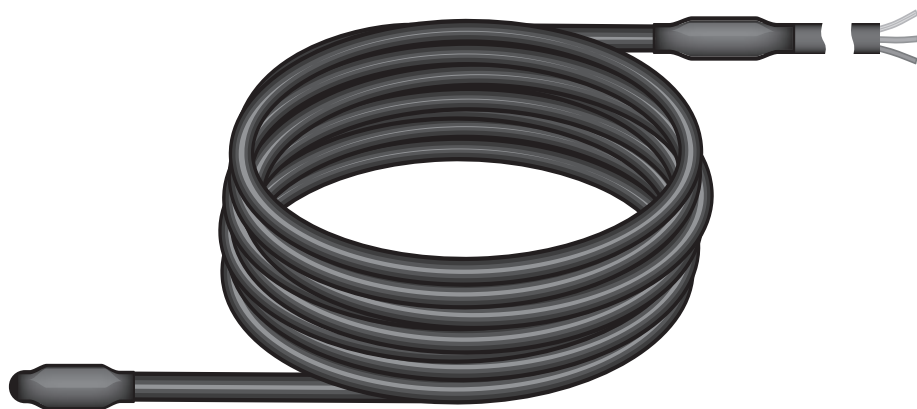

Scan om de handleiding in
andere talen te vinden.



INHOUD

1. ALGEMENE BEPALINGEN EN AANBEVELINGEN	2
2. DOEL	2
3. UITRUSTING *	3
3.1 AF FABRIEK GEMONTEERDE VERWARMINGSKABELSET	3
3.2 CONSTRUCTIE VAN DE VERWARMINGSKABEL	4
3.3 INSTALLATIE MET MONTAGETAPE	4
4. VOOR INSTALLATIE	5
4.1 BEPALING VAN DE INSTALLATIEPLAATS VAN DE THERMOSTAAT	6
4.2 THERMISCHE ISOLATIE	6
4.3 AANBEVOLEN SNIJDEEL VAN DE VLOERVERWARMING	7
4.4 INSTALLATIESTAP VAN DE VERWARMINGSKABEL	8
5. INSTALLATIE	9
5.1 STAP-VOOR-STAP INSTALLATIEHANDLEIDING	10
6. GEBRUIK VAN DE VLOERVERWARMING STARTEN	12
7. GEBRUIKSVOORSCHRIFTEN EN VEILIGHEID	13
8. GARANTIE	15
9. GARANTIECERTIFICAAT	16
KAMERPLAN	17
VOOR NOTITIES	18



Geachte klant, bedankt dat u voor een Grand Meyer-product hebt gekozen. Wij zijn ervan overtuigd dat onze producten aan uw verwachtingen zullen voldoen en uw huis warm zullen houden. Lees de instructie zorgvuldig door voordat u met de installatie begint. Het niet naleven van de regels en aanbevelingen voor de installatie van het vloerverwarmingssysteem kan leiden tot storingen van het systeem of een vermindering van de efficiëntie.

1. ALGEMENE BEPALINGEN EN AANBEVELINGEN

Voordat u de verwarmingskabel installeert, moet u ervoor zorgen dat het systeem dat u kiest geschikt is voor uw ruimte, rekening houdend met de oppervlakte ervan.

De instructie zal u uitvoerig vertrouwd maken met de installatie en aansluiting van Grand Meyer-vloerverwarming, aangezien de langdurige werking van vloerverwarming in grote mate afhangt van de correcte installatie. Installeer het systeem strikt in overeenstemming met deze handleiding. Installatie en aansluiting van de verwarmingskabel moeten worden uitgevoerd door een gekwalificeerde specialist.

2. DOEL

Grand Meyer-vloerverwarming is een elektrisch kabelverwarmingssysteem voor ruimteverwarming, gebaseerd op het leggen in een laag cement-zanddekvloer met een hoogte van minimaal 3 cm.

Grand Meyer-vloerverwarming op basis van verwarmingskabel THC20 is ontworpen om thermisch comfort in ruimten te bereiken en dient om:

- een comfortabele oppervlaktetemperatuur van de vloer te waarborgen;
- of de hoofdruimteverwarming (als enige warmtebron of als aanvullende verwarming).

Het vloerverwarmingssysteem, bedoeld voor de hoofdverwarming, moet ten minste 70% van het totale vloeroppervlak beslaan. De plafondhoogte mag niet meer dan 4 m zijn.



3. UITRUSTING *.

De Grand Meyer-set op basis van THC20-verwarmingkabel omvat:



1. Af fabriek gemonteerde verwarmingskabelset THC20 met 3 m koude aansluitkabel.



2. Geribbelde buis Ø 16 mm, lengte 1,5 m met een plug aan het uiteinde. De buis dient voor de montage van de temperatuursensor.



3. Installatie- en gebruiksinstructies.

4. Technisch gegevensblad van de af fabriek gemonteerde verwarmingskabelset THC20 met zijn technische kenmerken.

* Naast de set moet een kamertemperatuurregelaar worden geselecteerd (niet inbegrepen in de set).

3.1. AF FABRIEK GEMONTEERDE VERWARMINGSKABELSET.

De ondervloerse af fabriek gemonteerde verwarmingskabelset (hierna «verwarmingskabel») is gebaseerd op geïsoleerde tweekernige verwarmingsgeleiders, uitgerust met een installatie-koude aansluitkabel van 3 m lang voor aansluiting op de hoofdvoeding. Het specifiek vermogen van de kabel is 20 W/m bij een netspanning van ~230 V. Technische gegevens van de vloerverwarmingskabel THC20 worden weergegeven in tabel 1.

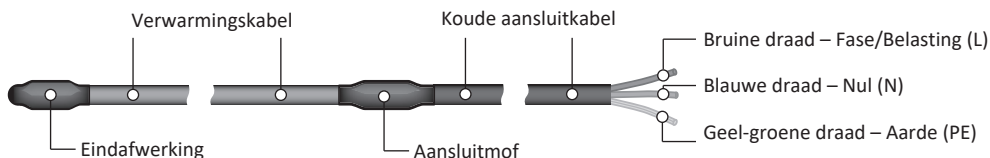

Bij aansluiting van de verwarmingskabel op het lichtnet: bruine en blauwe draad – verwarmingsgeleiders (belasting), geel-groene draad – afscherming (aardingsgeleider van het voedingsnet – PE).



3.2 CONSTRUCTIE VAN DE VERWARMINGSKABEL

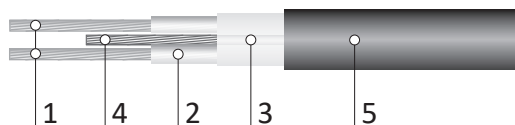

1. Tweekernige verwarmingsgeleiders.
2. XLPE interne isolatie.
3. Aluminium foliescherm.
4. Aardingsdraad.
5. PVC-buitenmantel.

Het lineaire vermogen van de verwarmingskabel is 20 W/m, de buitendiameter is 5 mm, de minimale buigradius is 60 mm. Technische gegevens van verwarmingskabel THC20 worden weergegeven in tabel 1.

Tabel 1. Technische gegevens van verwarmingskabels THC20.

Artikel	Lengte van de verwarmingskabel, m	Vermogen, W	Bedrijfsstroom, A	Weerstand, Ohm (bij +20°C)
THC20-10	10	200	0,9	251 - 291
THC20-15	15	300	1,4	168 - 194
THC20-23	23	460	2,1	109 - 127
THC20-32	32	640	2,9	79 - 91
THC20-45	45	900	4,1	56 - 65
THC20-57	57	1140	5,2	44 - 51
THC20-70	70	1400	6,4	36 - 42
THC20-85	85	1700	7,7	29 - 34
THC20-98	98	1960	8,9	25 - 30
THC20-115	115	2300	10,5	21 - 25
THC20-160	160	3200	14,5	15 - 19

3.3. INSTALLATIE MET MONTAGETAPE

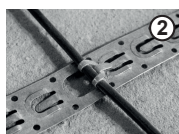
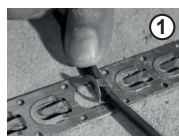

Montagetape is een van de montage methoden voor het leggen van verwarmingskabel met een constante spoed en het bevestigen ervan op het vloeroppervlak. Elke tapeclip heeft een gevouwen lip en een nok. De nok steekt boven het oppervlak van de tape uit, wat het gemakkelijker maakt om deze te buigen, bijvoorbeeld met een schroevendraaier.

Een kleine buiging aan het uiteinde van de lip zorgt voor een veilige bevestiging van de kabel "in het slot" (Fig. 1, 2).



Any heating cable must be connected through an RCD (Residual Current Device) whose rated operating current does not exceed 30 mA.

Table 2. Parameters of standard electric wire.

Conductor Material	Section, mm ²	Max. load current, A	Total load (max.) power, W
Copper	2x1,0	16	3500
	2x1,5	19	4100
	2x2,5	27	5900
Aluminium	2x2,5	20	4400
	2x4,0	28	6100

When floor heating is installed in wet rooms (bathrooms, saunas, swimming pools), the cable drain wire of the heating cable must be connected to the grounding conductor. Room thermostat must be installed outside the room with high humidity (bathrooms, toilets, saunas, swimming pools).

4.1. DETERMINING THE INSTALLATION PLACE OF THE THERMOSTAT.

The thermostat must be located outside of high humidity areas. The recommended installation height is 0.8 m from the floor surface. It is desirable that the thermostat has easy access to change the temperature level or program settings.

4.2 THERMAL INSULATION.

In order to reduce heat loss for heating the floor, ground and other structures lying below your premises, before installing the underfloor heating system, it is necessary to choose and install the thermal insulation correctly. With its help, you can significantly save the electricity consumed by the system.

If floor heating is used as the main heating system, we recommend using solid grades of expanded polystyrene (EPS) with a thickness of 20 mm or more with a density of at least 35 kg/m³.

Thermal insulation should be used in all cases if the floor is located close to the ground or in the basement.



For basements, garages and other premises where the floor is in direct contact with the ground, it is recommended to use rigid foam or mineral wool boards with a thickness of 30 mm or more.

The insulation material is laid or glued to the concrete floor. To prevent deformation of the floor during heating, shock-absorbing strips of sheet foam are glued around the perimeter of the room. The thermal insulation layer is poured with a floor leveler and a screed is made.

Without additional thermal insulation, the heating time of the floor increases.

The thinner the layer of additional thermal insulation, the more heat is lost downwards, and the less heat is released into the room.

If there is a warm room under you, then the thermal insulation may not be laid, but in any case, the best solution is to isolate the warm plate with a heating cable from the concrete base, as it increases the efficiency of the system.

4.3 RECOMMENDED CUT OF THE FLOOR HEATING.

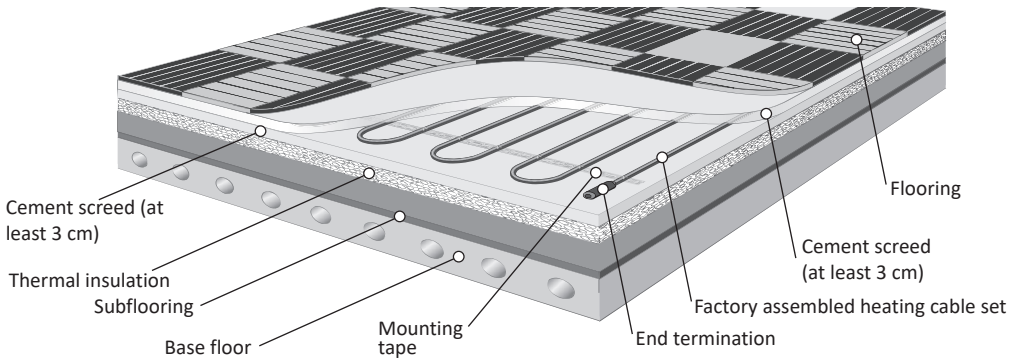

Laminate, linoleum, carpeting, etc. can act as a decorative coating.

If ceramic tiles are used, they are usually attached to the screed with a heating cable using tile adhesive.

If ceramic tiles are used, the heating cable must not be laid directly into the tile adhesive layer, except for a cement screed. This can lead to cracking of the floor surface and failure of the heating cable.



If the floor heating system is used to ensure a comfortable temperature of the floor surface and there is a warm room below, for example, a city apartment (not the first floor), then the thermal insulation can not be laid.

4.4 INSTALLATION STEP OF THE HEATING CABLE.

Before starting installation, after choosing the heating cable you need, you need to determine its laying step, which can be calculated using the formula:

STEP laying (cm) = **(100 x S) / L cable**, where

S - is the actual area on which the heating cable is laid (m²),

L cable - is the length of the heating cable (m).

The calculated laying step is rounded up to a multiple of 2,5 cm, since the clamps on the applied mounting tape, into which the heating cable is attached, are located 2,5 cm apart.

It should be noted that the above formula does not take into account the length of the cable bends at the turns.

For a more correct calculation of the heated area, we recommend to use the drawing software.

Depending on the specific power (type of heating - maintaining a comfortable floor temperature or main heating) of the heating cable system, the heating area and the step of laying the heating cable depend. This dependence is shown in Table 3.

Table 3. Recommendations for the selection of heating cables.

Article	Length, m	Power, W	Max. heating area (m ²) at laying step (specific power, W/m ²)				
			7,5 cm 267 W/m ²	10 cm 200 W/m ²	12,5 cm 160 Вт/м ²	15 cm 133 W/m ²	17,5 cm 114 W/m ²
THC20-10	10	200	0,75	1,00	1,25	1,50	1,75
THC20-15	15	300	1,13	1,50	1,88	2,25	2,63
THC20-23	23	460	1,73	2,30	2,88	3,45	4,03
THC20-32	32	640	2,40	3,20	4,00	4,80	5,60
THC20-45	45	900	3,38	4,50	5,63	6,75	7,88
THC20-57	57	1 140	4,28	5,70	7,13	8,55	9,98
THC20-70	70	1 400	5,25	7,00	8,75	10,50	12,25
THC20-85	85	1 700	6,38	8,50	10,63	12,75	14,88
THC20-98	98	1 960	7,35	9,80	12,25	14,70	17,15
THC20-115	115	2 300	8,63	11,50	14,38	17,25	20,13
THC20-160	160	3 200	12,00	16,00	20,00	24,00	28,00



5. INSTALLATION.

The installation of the heating cable must be carried out by a qualified specialist, the connection of the underfloor heating cable system to the electrical network must be carried out by a certified electrician.

The heating cable is laid on open flooring surfaces. The laying step must be such that the power per unit area corresponds to the calculated one - see section 4.4 (table 3) of this Instruction.

The heating cable is laid on a flat floor base, without significant protrusions and height differences. If there are protrusions and height differences, the thickness of the subsequently poured screed will be different over the entire floor heating area, which will lead to uneven heating of the floor.

For correct and reliable fastening of the heating cable, a mounting tape with a fixing pitch of 2,5 cm is used (see cable 3.3). The mounting tape is attached to the floor in any way - with nails, dowels, glue, etc., in increments of 50 - 150 cm, depending on the configuration of the room. Permissible bending diameter of the fixed cable - 6 cm.

The distance between the lines of the heating cable should be no more than 18 cm, otherwise a temperature difference will be felt on the floor surface - alternation of warm and cold zones. For wet rooms, a laying step of no more than 15 cm is recommended.

Between the lines of the heating cable, a corrugated tube is laid and fixed, inside which a temperature sensor is installed. Along the corrugated tube in the wall, the sensor, together with the installation conductor of the heating cable, is led to the place where the thermostat is installed. The corrugated tube must be plugged from the side of the sensor to prevent the solution and moisture from getting inside when pouring the screed.

Immediately after the installation of the floor heating is completed, it is necessary to draw the final laying plan with binding in place, indicating the location of the joint and end sleeves, temperature sensor, lines of the heating cable.

The laid and securely fixed heating cable is poured with a cement screed, the thickness of which should be from 30 to 50 mm.

Cement screed should not have sharp stones and air pockets, so as not to damage the heating cable and prevent it from overheating.



In the process of laying the heating cable it is necessary to control the integrity of the cable and the corrugated tube.

Attention!

It is forbidden to turn on the heating cable until the screed is completely hardened. Generally, this time is 30 days.

5.1 STEP-BY-STEP INSTALLATION GUIDE.



1. Cut through a 2,5 x 2,5 cm heating cable in the wall and floor. It is necessary for laying the temperature sensor, the installation conductor and for installing the mounting box for room thermostat (Fig. 1).



2. Clean the base on which the heating cable is laid from garbage and sharp objects (Fig.2).



3. Fasten the mounting tape to the floor (Fig. 3).

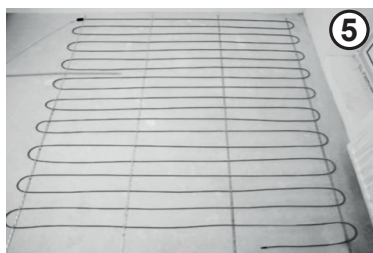

4. Lay out the heating cable evenly in loops over the surface of the entire floor, avoiding pipes and areas intended for bathrooms, cabinets, etc. Fasten the heating cable to the mounting tape using special clamps. The lines of the heating cable must not intersect or touch each other (Fig. 4, 5).

To prevent longitudinal movement of the heating cable due to heating during operation, it should be laid in one direction for a length of no more than 6 m.



5. After laying the heating cable, check electrical resistance measure. The electrical resistance of the heating cable must match the specified in the technical data sheet for the heating cable. Allowed deviation from the specified parameters -5% - +10% at $t = 20 \pm 1^\circ\text{C}$ (Fig. 6).



6. Place the floor temperature sensor in a corrugated pipe, plugged at one end to prevent mortar and moisture from getting inside when pouring the screed, and place it between the heating cable lines on the open side of the loop at a distance of 50 - 60 cm from the wall (Fig. 7).

Lay the corrugated pipe with cold lead of the heating cable in a chase in the wall leading to the junction box.



7. Connect the cold lead of the heating cable with the room thermostat. (Fig. 8).

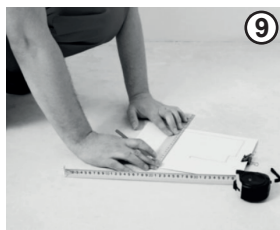

8. Draw the room plan with heated area location, indicating the heating cable end and splices, temperature sensor and the place of connection to the power supply (Fig. 9). If heating cable breakdown will be made during installation, it will help to identify breakpoint to fix the heating cable.

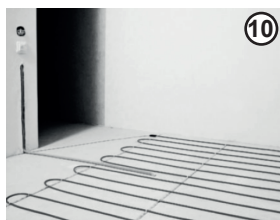

9. After installation (Fig. 10), lay the cement screed on the heating cable. The heating cable, end and splices must be completely filled. In case of incorrect filling or poor-quality of the screed, air pockets can form around the cable which can lead to an excess of the permissible temperature on the cable surface and, consequently, to its damage.

10. Check measure of the electrical resistance of the heating cable after pouring the screed again.

11. After the screed has completely hardened (usually 30 days), you can turn on the warm floor.

6. STARTING USE THE UNDERFLOOR HEATING.

You can turn on floor heating after the tile adhesive has completely dried (you can specify this parameter in the technical specifications on the package of the tile adhesive). Turn on the room thermostat and set the desired temperature on it, using the instructions of room thermostat* (not included in the set).

When you turn on the floor heating for the first time after installation,



you can set the maximum level of heating and, after reaching a comfortable temperature, reduce the level. When you turn on the floor heating for the first time, it can take up to 48 hours to reach desired temperature, depending on the parameters of the room.

7. OPERATING RULES AND SAFETY.

- The braided shield of the heating cable power cable must be permanently and securely connected to the earth terminal in the junction box or to the appropriate terminal on the thermostat.
- On the floor made of materials with good thermal conductivity (ceramic tiles, natural stone, etc.), under which the floor heating cable is installed, there should not be any other coatings and objects (carpets, blankets, etc.) that prevent heat transfer, to avoid cable overheating.
- The heating cable must be at least 50 mm away from walls, furniture and any other objects that prevent effective heat release into the air.
- When installing the heating cable, direct contact with the thermal insulation, if it is corrosive, hygroscopic or flammable, must be excluded.
- The surface of the floor with installed heating must not be subjected to mechanical stress (it is forbidden to hammer nails, dowels or screw in screws, etc.) in order to avoid damage to the heating cable and temperature sensor.
- In case of a long absence from the room during the cold season, we recommend disconnecting the system from the power supply or not turning off the heating completely, but setting it to the minimum level. In this case, the system consumes little energy, and the room will not be completely cold and it can be heated up more quickly after your return.
- It is forbidden to make any changes to the design of the heating cable received from the manufacturer, with the exception of cutting the mesh when laying.
- It is forbidden to replace the installation wires yourself by breaking the connections in the coupling made by the manufacturer.
- It is forbidden, even for a short time, to turn on the heating cable rolled into a roll into the electrical network.



- It is forbidden to connect heating cable to the electrical network, the voltage in which does not correspond to the operating voltage specified in the technical data sheet for the heating cable.
- The heating cable must be connected by a qualified certified electrician.
- During installation, the heating cable must not be exposed to oil, grease or other similar substances.
- To avoid mechanical damage to the heating cable, installation must be carried out in shoes with soft springy soles or cover the surface with the heating cable laid out on it with plywood sheets or some other materials that prevent mechanical impact on the heating cable when walking on it.
- It is forbidden to use heating cable without a minimum layer of tile mixture that completely covers the heating cable. The thickness of the tile mixture should be 5-8 mm, the formation of bubbles and the rise of the heating cable are not allowed.
- It is forbidden to subject the floor surface under which the heating cable are installed to any mechanical influences.
- If any of the above requirements is violated, the manufacturer will void the warranty.



8. WARRANTY.

The manufacturer guarantees the operation of the THC20 heating cable for 20 years, subject to compliance with all the requirements set forth in this Installation and Safety Manual.

The manufacturer undertakes to carry out a warranty repair of the heating cable if all the requirements for installation and operation rules are met, upon presentation of the completed Warranty Certificate and the Room Plan indicating the location of the room thermostat, heating cable, splice, end sleeves and floor temperature sensor.

Products with defects resulting from mechanical damage or improper connection and operation of the heating cable are not subject to warranty repair.

MANUFACTURER:

SIA «PRIOTHERM»

Address: st. Augusta Deglava 50, Riga, LV-1035, Latvia.

info@grand-meyer.com

www.grand-meyer.com



9. WARRANTY CERTIFICATE.

Heating cable used for Comfort/Basic heating.
(cross out the unnecessary)

Room type _____

Total room area _____ m²

Floor heating is installed on the square _____ m²

Heating cable _____
(Article)

Presence of thermal insulation (YES/NO), its type and thickness _____
(cross out the unnecessary)

Sale made _____

Contact number _____

Date of sale _____ 20____ r. Seller _____
(signature)

Shop stamp _____ Buyer _____
(signature)

System installed _____

Contact number _____

Installation date _____ 20____ r. Installer _____
(signature)

The floor plan is attached.

Room plan.

Room plan indicating the location of the temperature regulator, floor temperature sensor, heating cable, connection splice and end termination for installation purposes and for searching of possible defects.

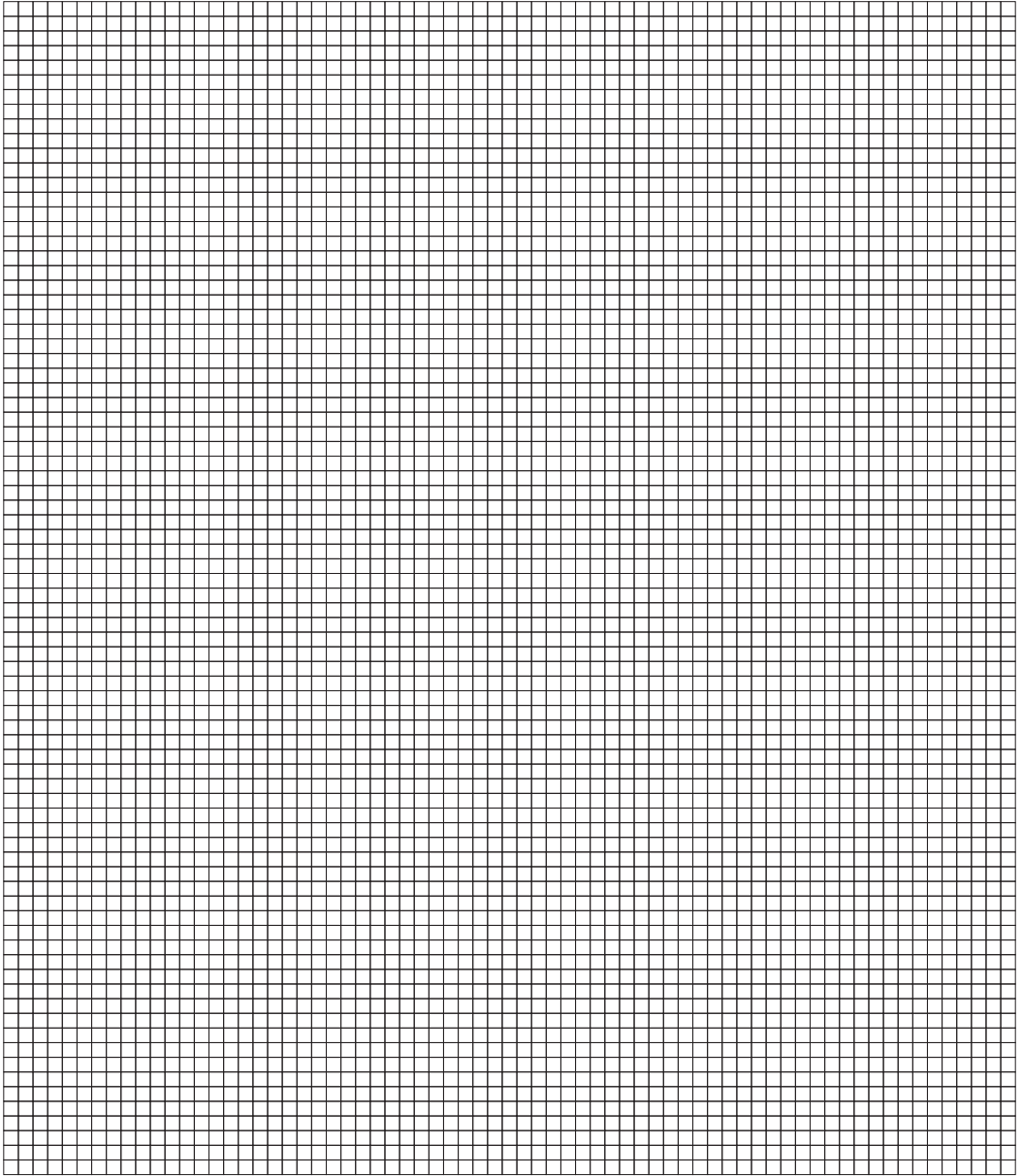

Type codes

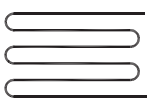

Heating cable

Corrugated tube for temperature floor sensor

R heating cable Ohm



Temperature Sensor



Room Thermostat



Connection Splice



End Termination

R sensor Ohm

